

Specification for 5050SMD Pixel Dot

Applications:

Suitable for cove and contour lighting etc. in KTV, hotel, shopping mall, home, cabinet and so on

Features:

1. RGB 5050SMD LED mounted, 3leds/pcs or 6leds/pcs
2. DC12V for 3leds, DC24V for 6leds
3. 115 Viewing angle
4. Certificate: CE,RoHS
5. Warranty: 2 years
6. Each unit can be cut
7. 1pcs 1903 IC per unit
8. PVC Cover & Epoxy
9. Can controlled by SD card controller

Picture:



Model: PD35-3D



PD40-3D



PD40-6D

Drawing:

For PD35-3D

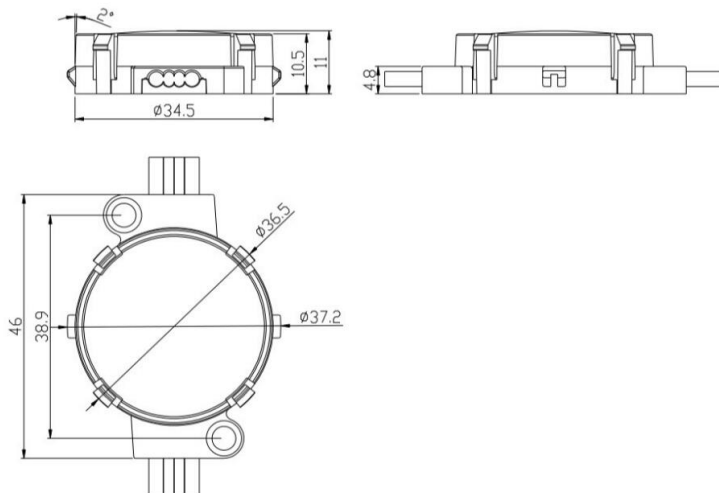

For PD40-3D and PD40-6D

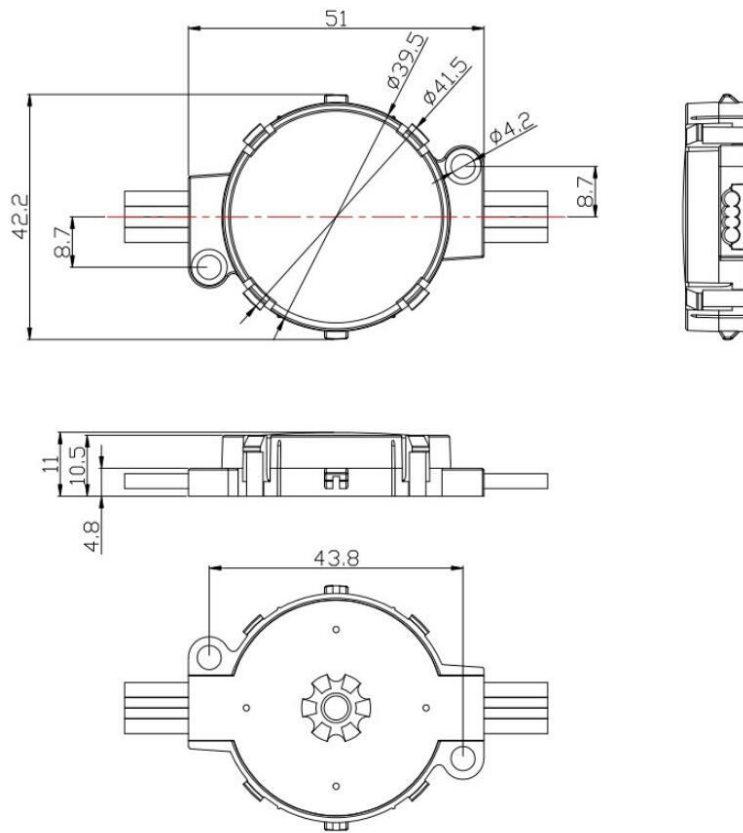

Specification:

Part No	PD35-3D	PD40-3D	PD40-6D
Dimension	Φ 35mm	Φ 40mm	Φ 40mm
LED No.	3	3	6
IC No.	1	1	1
Voltage	DC12V	DC12V	DC24V
View angle	115	115	115
Current (mA/pcs)	60 mA	60 mA	60 mA
Power (w/pcs)	0.72W	0.72W	1.44W
Color	Pixel	Pixel	Pixel
Controller	SD card controller	SD card controller	SD card controller
Operating Temperature	-25°C - 60°C		
Storage Temperature	-30°C - 60°C		
IP	65		